

CAD FILE:

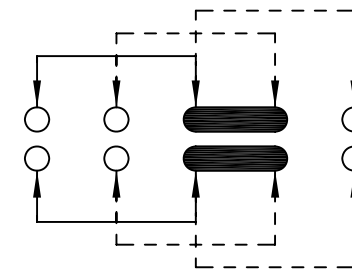
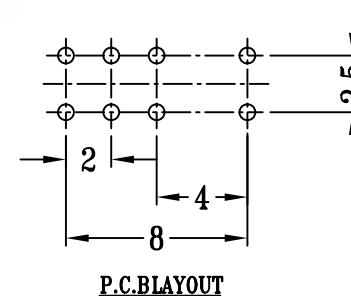
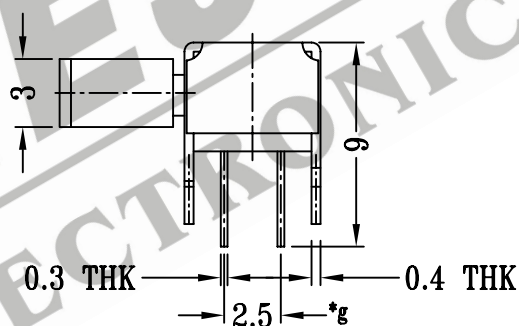
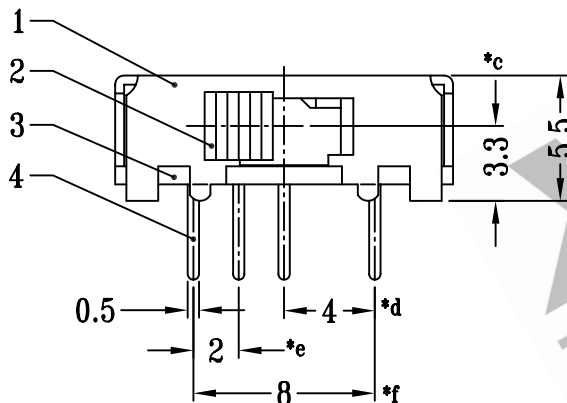
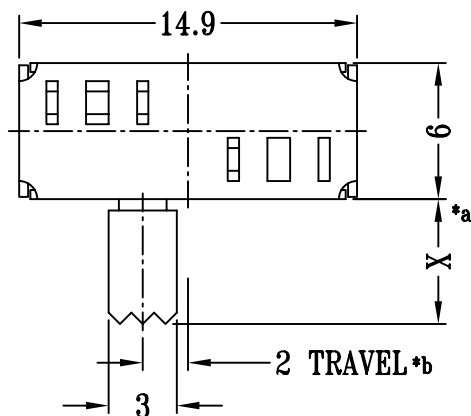

SCHEMATIC (SHORTING)

注:带"\*"表示关键尺寸(7个)

				TOLERANCE UNLESS SPECIFIED		SHENZHEN XIEJIA ELECTRONICS CO.,LTD.				
				WITHIN : 1.5±0.1mm		ISSUE	DATE	DESCRIPTIONS		APPD.
				OVER : 1.5±0.2mm				TITLE : HORIZONTAL SLIDE SWITCH		
8										
7										
6	SPRING PLATE	STAINLESS STEEL	1	NATURAL						
5	CONTACT CLIP	PBS	2	Ag CLAD						
4	TERMINAL	BRASS STRIP	8	Ag PLATED OVER Ni PLATED	MODEL: SK-23D08		SCALE: 3:1	CHK'D	FANGYING	2003-6-5
3	BASE	PHENOLIC RESIN	1	NATURAL	ALL MATERIALS MUST BE COMPLIANT TO ROHS			APPD.	KANGXINAN	2003-6-5
2	KNOB	POM	1	RED						
1	FRAME	STEEL STRIP	1	Ni PLATED						
NO.	PART NAME	MATERIAL	Q'TY	FINISHING						